



HQ Racing Australia Inc.

**HQ Racing Technical
Regulations**

2020



HORA Inc, Category representatives to CAMS

OBJECTS

To foster and promote the sport of circuit motor racing in Australia with particular emphasis on the HQ Holden Class as recognized by the Controlling body.

To provide the HQ Holden Class as a low cost, properly and well organized circuit motor racing category.

To police the HQ Holden Class strongly to provide fair competition for all.

To always keep the regulations of the HQ Holden Class simple, straightforward, and adhering to the principal that "The vehicles are to remain standard unless specifically stated otherwise".

To never allow any freedom within the regulations of the HQ Holden Class that will allow the Class to deviate from its roots of providing low cost circuit motor racing.

That no points be awarded in any state championship conducted on the same weekend as the Nationals, except for the host state who may make that decision to suit their unique circumstances.

To seek out its own sponsorships and at all times be self funding and financially independent of any other club or organization, save for the relationship with each State Association listed in rule number 16.2.1 (sixteen point two, point one).

To have a united body of competitors able to negotiate with circuit motor racing promoters and Motorsport Australia as the Controlling Body of the sport for the benefit of the HQ Holden Class.

To provide the means by which anyone wishing to enter, continue or re-enter circuit motor racing can do so at a very realistic cost.

To regularly review the suitability of the HQ Holden Class for circuit motor racing in Australia, and to be in the position of providing a suitable replacement if and when the need arises and is agreed to by each of the Member Associations.

SOCIAL MEDIA POLICY

Social networking, media and content sharing sites are online tools that allow people to communicate via the internet. This includes, but is not limited to:

- External social networking sites (e.g. Facebook, Twitter).
- Online discussion forums and blogging sites.
- Video and photo sharing websites (e.g. Flickr, YouTube).
- Any other websites that allow individual users to publish information. In online social networks it can be difficult to draw the boundaries between public and private and your personal and professional views. As our sponsors, national bodies, members and the public may have access to the information you publish, it is essential that you apply good judgement and common sense when using social networking media to ensure HQRA's reputation is not harmed. HQRA does not wish to control your personal use of social networking media. However, HQRA requires that you comply with this policy if you.
 - Make reference to HQRA, either directly or in a manner that could be easily inferred as referring to HQRA, its operations, members, events or executive board. or
 - Identify yourself as a person who is a member of HQRA in these instances you are required to.
 - Only post information using your own name, and not use the identity of any other person (including name, nickname etc).
 - Not use HQRA's logos in your postings (unless properly authorised to do so by HQRA).
 - Only disclose information that is publicly available. You must not comment on or disclose confidential HQRA information (e.g. Information obtained in the course of your membership at HQRA, other members information, information about HQRA's operations or executive board etc).
 - Ensure that any content you publish is factually accurate and complies with any applicable HQRA policies (e.g. Privacy and Confidentiality Policy) and any applicable laws (e.g. Copyright).
 - Behave in a polite and respectful manner, and ensure that you do not cause damage to HQRA or bring its reputation into disrepute (e.g. Disparage or speak adversely about HQRA, including its members, sponsors, promoters, events, national bodies or executive board).
 - You should speak with your State Delegate before you post information on the internet if you are unsure if the content would breach this policy; HQ Racing Australia Specifications, You must not purport to speak on behalf of HQRA (or its affiliated associations) through social media channels unless you are authorised, or you have the express prior written approval from the HQRA Executive Board. Members are reminded that this policy not only applies to those who may be the original publisher of the comment or information, but also to any member who subsequently responds or replies to any social media post in a manner that contravenes this policy. This policy applies to all persons who are members of a State Association which is affiliated with HQRA.

PENALTIES

A member is guilty of Misconduct if they breach this policy and engage in conduct, which in the absolute discretion of HQRA, would or would likely bring the member, the sport of HQ Holden racing, HQRA or an Affiliated Association into disrepute.

The maximum penalty imposed on a member guilty of Misconduct shall be: -

- (a) a \$5,000 fine; and/or.
- (b) Two (2) year Suspension.

Administration

- | | | |
|-------------------------------------|---|---|
| <u>National Administrator</u> | - | David Ling
PO Box 630 PARAP NT 0804
(W) 08 89477099
(M) 0412 336153
(F) 08 89843527
david@aussienascartours.com.au |
| <u>Secretary</u> | - | Sue Ashlin
(M) 0438 516370
suzanne.ashlin@justice.tas.gov.au |
| <u>Treasurer</u> | | Tanya Cambridge
(M) 0417 048365
dtctanya@yahoo.com.au |
| <u>National Eligibility Officer</u> | - | Colin Roper
(M) 0417 355512
ciroper@bigpond.com |
| <u>State contacts</u> | - | QLD - Brad Schomberg (President)
(M) 0438 008303
bschombi@dodo.com.au |
| | - | VIC - Rod Raatjes (Delegate)
(M) 0419531348
rod.raatjes@securitymerchants.com.au |
| | - | South Aust - Darren Jenkins (Delegate)
(M) 0438 270640
oldreynellacrash@bigpond.com |
| | - | West Aust - Laurie Marsh (Chairman)
(M) 0418535956
patiodude1@hotmail.com |
| | - | NT - Gavin Thompson (Delegate)
(M) 0419 819017
tommohq73@hotmail.com |
| | - | TAS - Wayne Nicholls (Delegate) |

(M) 0439 354606
parkside@bigpond.net.au
- NSW - Duane Cambridge (President)
(M) 0417 414419
dtcduane@yahoo.com.au

Life Members

Les Morrall

Robert Kramer

Ian Beechey

Dale Youd

Colin Roper

Graham Boulter

Gavin Porteous

David Ling

Past Champions

Year	Track	Driver	Year	Track	Driver
1989	Winton	Richard Whyte	2005	Winton	Peter McNiven
1990	Winton	Bruce Williams	2006	Hidden Valley	Layton Crambrook
1991	Winton	Geoff Manson	2007	Willow bank	Gary Bonwick
1992	Bathurst	Peter Hopwood	2008	Baskerville	Gary Bonwick
1993	Symmons Plains	John Talbot	2009	Eastern Creek	John Wood
1994	Lakeside	Paul Ramano	2010	Wanneroo	Gavin Porteous
1995	Mallala	David Lines	2011	Mallala	Bruce Heinrich

1996	Wanneroo	David Lines	2012	Sandown	John Wood
1997	Baskerville	Neville Haley	2013	Hidden Valley	John Wood
1998	Not Held		2014	Morgan Park	Bruce Heinrich
1999	Bathurst	Peter Dane	2015	Symmons Plains	Rod Raatjes
2000	Lakeside	Craig Yates	2016	Wakefield	Brett Osbourne
2001	Hidden Valley	Peter Holmes	2017	Wanneroo	Brett Osbourne
2002	Not Held		2018	Phillip Island	Rod Raatjes
2003	Wanneroo	Tony James	2019	The Bend	Joel Heinrich
2004	Mallala	Steve Laybourn			

Recognition Document

To be read in conjunction with the Motorsport Australia Manual of Motor Sport

1. Model

Descriptions used by the manufacturer for identification and easier ordering of eligible vehicles are:

Holden four door sedan	HQ80169
	HQ80269
	HQ80369
	HQ80469
	HQ81169
	HQ81269
	HQ8M69
	HQ8N69
	HQ8P69

2. Dimensions

2.1	Minimum racing weight (with driver)	1365 kg
2.2	Overall length	4810 mm (max)
2.3	Overall width (measured at the centre of the respective axle)	Front 1903 mm Rear 1886 mm

2.4	Wheelbase (maximum)	2847 mm
2.5	Track (maximum)	Front 1631 mm Rear 1590 mm

To determine the track of any vehicle the following procedure is to be followed: -

- The vehicle should be in a “ready to race” condition but, without the driver aboard
- Determine the centre of the tread of each tyre, at the same height above the road, and mark that space with a spot of paint
- The centre should be determined using the full width of the tyre, ie the extremities of the bag
- The vehicle should be rolled forward so that it leaves 2 marks on the road
- Measure the distance between the centre of the marks to determine the track

2.6	Ride height (Minimum ground clearance for any sprung component of the vehicle, excluding exhaust. Measured without Driver.)	100 mm
-----	--	--------

2.7 Save for stitch welding of the front lower rear control arm mounts, welding adjacent to the existing mounting rivets, no longer than 25mm is permissible for the purpose of preventing cracking.

3. Engine

3.1	Number of engine mounts	2
3.2	Bore Stroke :	93.83mm (3.694") 82.50 mm (3.250")
3.3	Pistons	Material : Aluminium Type : Cast (not forged) No. of rings : 3 (one ring or assembly per ring groove) Maximum Diameter 93.65 mm (3.687") (measured 51mm (2.00") from top of piston)

Pistons as are shown in a widely distributed catalogue must have three ring grooves, each of which must be fitted with piston rings as supplied by a ring manufacturer. The piston crown maybe machined for the purpose of reducing compression.

Any machining of the piston bowl is to be of concave shape, concentric to the centre of the piston and perpendicular to the cylinder bore, save for the walls of the bowl formed to achieve the desired depth.

3.4	Connecting rods (Standard type) (centre to centre)	5.250 “
	Minimum weight	460 g

The use of aftermarket con rod bolts is permissible. No modification or machining of the con rod is permissible for the purpose of con rod bolt fitment.

3.5	Gudgeon pin (Standard type) Pressed in-no circlip	0.866”
-----	--	--------

3.6	Cylinder block	(Red, Blue and Black Engine Block) 202/3300 (casting made on left of block)
-----	----------------	--

It is permitted to use any Holden 202 or 3.3 Red, Blue or Black engine block, six-cylinder in-line engine. With regard to a blue or black block ONLY. It is permitted to re-sleeve two cylinders only and bore to suit pistons as per rule 3.3 of this manual. It is permitted to re-sleeve all cylinders on a red block to suit pistons as per rule 3.3 of this manual. Local machining of later blocks to facilitate fitment of 202 (2811930 and 9937262) cylinder heads only is allowed. Any and all engine ancillary components must comply with original HQ Holden specifications. It is not permitted to use any non HQ Series components. (Except as authorized in these regulations). The use of titanium components is prohibited.

3.7	Cylinder head	(Cast numbers)	2811930 9937262
-----	---------------	----------------	--------------------

Cylinder head: The cylinder head must be of the large combustion chamber type, using bridge type rocker gear. Casting numbers are: 2811930 / 9937262. Facing or shimming of the rocker bridges is permitted. Six-cylinder rocker arms (PN 2811931 or 92018908) must be used. Adjustable push rods are permitted to a maximum length of 9.030"

The minimum unswept volume achieved by the sum total of combustion chamber, piston bowl and any positive deck volumes measured at top dead centre shall be 45 cc. per cylinder. Any machining of the piston bowl is to be of concave shape, concentric to the centre of the piston and perpendicular to the cylinder bore, save for the walls of the bowl formed.

Unswept Volume Procedure

1. Start with CLEAN (as in spotless) heads.

2. Be sure to use the same type of spark plugs for CCing that you intend to run.
3. Block the head up so that the head surface is flat and even.
4. Coat the periphery of the combustion chamber with grease – white heat-resisting brake grease is easy to see and works very well.
5. Place the HQRA approved Plexiglas plate over the chamber, with the hole on the high side and the counter sink up. Press evenly and firmly to insure a perfect seal.
6. Carefully assemble the burette (type as specified by HQRA), stand and clamp.
7. Using clean blue kerosene as the measuring fluid, fill the burette to the “O” line. NOTE: The surface of the column of fluid will appear to be concave (or sunken) in the center. This is known as *meniscus*. For accurate results, align the marks on the burette with the lowest (sunken) portion of the fluid for all measurements.
8. With the burette positioned over the countersunk hole, and the head FIRMLY blocked, slowly open the stop-cock and begin filling the chamber. Watch for leaks at the seal of the plate and the head surface (this is where the white grease helps). If a leak develops, be very patient and START OVER.

Specification of Burette ‘Cat No: 13918, ISO 9001-14001certified’

9. Fill the chamber until the fluid just touches the BOTTOM of the hole. Be sure ALL air bubbles are out.
10. Carefully read and record combustion chamber number of the amount of liquid metered into the chamber. (Remember what was mentioned about meniscus.) For reference of rechecking the noted combustion chamber on the seal sheet is to be used.

Valve springs are free subject to there being only one single spring per valve save that the spring must be manufactured to a cylindrical shape, externally and internally.

It is permitted to fit shims under the valve springs. Valve spring shrouds may be removed. It is permitted to machine the valve spring seats to obtain correct installed height.

The method of valve retention must be as envisaged by General Motors Holden in this application. Planing of the cylinder head face is permitted subject to angle planing being prohibited. The rocker cover is free.

NOTE: The use of MLS (multi layered steel) type head gaskets is NOT permitted for use for the purpose of use as a head gasket.

3.8	Valve size	Inlet (max) Exhaust (max)	42.55 mm (1.675") 34.93 mm (1.375")
3.9	Flywheel (not including ring gear)	Diameter Minimum Weight Ring gear to clutch face	277.4 mm 9800 g 19.56 mm minimum

4. Induction

4.1	Carburettor	Number Type Code Numbers Venturi	1 Single throat downdraft Stromberg BXV-2 and BXUV-3 23-3052, 23-3053, 23-3075, 23-3076 23-3084, 23-3073, 23-3081, 23-3091, 23-3092. 30.94 mm
	Maximum size of the flange hole of carburetor exit port		36.40 (early) 40.00 (late)
4.2	Inlet manifold casting numbers		2820781 (early) 2825951 (late) (including HQ production variants (eg, 2820781-88-1).

An air cleaner (part number HQ900AL) as supplied by Speco Thomas or equivalent of same physical dimension and design must be used. The air filter element is free save that the element to be used must be circular with a diameter of 225mm and a height of 50mm, commercially available, unmodified from the manufacturer's specification and fits the current control air cleaner body.

4.3 It is permissible to use a maximum 2 exhaust/intake manifold gaskets with a maximum overall thickness of 3mm.

4.4 It is permissible to fit a heat shield as supplied by HQRA between the carburetor and the inlet manifold for the purpose of reducing engine bay heat into the carburetor.

5. Fuel System

5.1	Tank	Number	1
		Material	Steel
		Location	Under rear of vehicle
		Capacity	74 Litres
5.2	Fuel Pump	Number	1
		Location	RHS of engine block
		Type	Mechanical
		Part Number	7415943 (red engine/glass bowl) a 9206043(blue engine/no glass bowl)

A 12 volt solid state electronic fuel pump with an in built pressure regulator maybe fitted in place of the original mechanical fuel pump.

The electronic fuel pump will have a maximum manufacturer specification of 7 psi at the pump outlet. The fuel pump is to be fitted within 50 cms of the existing fuel tank outlet within the confines of the boot compartment.

Approved fuel line is to be used for the fitment of the pump utilising as much as practical of the existing standard fuel line. The existing fuel pump mount on the block must be blanked off using an after-market fuel pump blanking plate.

The fuel line to the carburettor will be by means of an approved fuel hose from the existing fuel outlet at the chassis rail to the fuel line from the existing fuel pump to carburettor fuel line. Wiring of the fuel pump will be in line with current electric fuel pump requirements Schedule C article 10 of the Motorsport Australia manual.

It is permitted to modify the fuel tank breathers with the addition of suitable tubing further the fuel sender float arm on the sender unit / fuel pick up assembly may be removed.

5.3 In order to retrieve fuel for testing purposes a valve and fittings as supplied by HQRA is to be fitted between the fuel pump and the metal fuel line to the carburetor at the fuel pump. When an electric fuel pump is used the FRD is to be mounted at the entry end of the unmodified carburetor fuel supply pipe.

6. Transmission

6.1	Clutch Driven Plate	Type Diameter	Diaphragm 219.08 mm (8.625")
6.2	Gearbox	Three Speed Cluster part number Ratios	7434307 1 st - 3.07:1 Teeth 17/27 2 nd - 1.68:1 23/20 3 rd - 1.00:1 29/15 Rev. 3.59:1
6.3	Final Drive	Ratio Number of teeth Type Shimming	3.55:1 39/11 Salisbury or Banjo Multiple shims Permitted.

Any suspended wheel must rotate freely at all times.

Gearbox: Only the original three-speed manual gearbox may be used. The extension housing may be replaced by an extension housing sourced from a four-speed, M20 or M21 gearbox. Local modification is allowed for the purpose of the retention of the rear main gear box bearing only.

The steering column gear linkage may be replaced by a floor shift mechanism, in which case it is permitted to modify the bodywork only as necessary for the fitment of the shift mechanism.

When we approved the use of the M20 and M21 extension housing, it was overlooked that this extension housing does not retain the rear gear box main bearing in the gear box housing.

The normal 3 speed housing is slightly different in structure that is designed to retain the rear bearing in the main housing. By allowing minor modification rectification of securing the rear main bearing is easily achieved. There is no performance or technical advantage that maybe achieved with this rule modification.

It is permissible to modify the bottom of a Salisbury differential housing for the purpose of fitting a drain plug with a means of safety wiring said plug.

7. Brakes

7.1	Master cylinder	Number	1
		Location	Firewall
		Bore	25.4 mm
		Power assistance	Yes
		Make & Model	PBR Master Vac
7.2	Rear Drums	Internal diameter	257 mm
		Number of shoes	2 (per side)
		Width of shoes	44.4 mm
		Length per shoes (Friction Material)	262.9 mm (maximum)
		7.3	Front Discs
Calipers per wheel	1		
Caliper material	Cast Iron		
Caliper part number	PBR LH 9933233 RH 9933234 Girlock LH 9929899 RH 9929900		
Disc Diameter	276 mm		
Maximum thickness	25.4 mm		
Ventilated	Yes		
Pad Surface	Refer to templates		

8. Suspension and Steering

8.1	Steering	Type	Recirculating ball
		Ratios	16.7:1 and 20.1
		Power assistance	Optional
8.2	Suspension	Front	Wishbone
		Rear	Trailing Arm
		Sway bar (front only)	Diameter 17.5 mm
8.3	Control suspension	As specified in Motorsport Australia manual	
8.4	Wheels	Diameter	14"
		Width (Front & Rear)	7" or 8"
		Tyre size	235/60x14
		Make of Tyre	Kenda Klever H/P KR15

- 8.5 Later RTS (radial tuned suspension) type chassis rails are not permitted.
- 8.6 It is permitted to use and fit front wheel bearing pre-load spacers.
- 8.7 The flexible steering coupling maybe replaced with any commercially available after market coupling. No modification of steering shaft is permitted for fitment of after-market coupling.

9. Tyres

Tyres shall be Kenda Klever H/P KR15 P235/60R1496H. All tyres must be marked by one of the state HQ Racing Associations. At any time during practice, qualifying or racing the depth of tread, when measured at any point other than the shoulder of the tyre, shall be not less than 1.5mm.).

10. Body

The interior must be complete as manufactured save that:

- floor coverings may be removed,
- seats may be removed and the driver's seat replaced with another in compliance with Schedule C (refer to Section 7 of the Motorsport Australia Manual of Motor Sport)
- hood lining may be removed
- door arm rests may be removed
- the steering wheel may be replaced
- the jack and spare wheel must be removed
- the kick panels, pillar linings, sun visors, rear parcel shelf covering and boot floor covering may be removed.
- door trims may be replaced by others of similar materials and appearance to the original
- washer bottle,
- horn. All roll cage protection/padding will be compliant with NCR's standard stated schedule J 11.2 (i.e. FIA Standard 8857-2001 or SFI spec 45.1)

A front panel (nose cone) made of a composite material is permitted.

It is optional to remove front inner guard rubber wheel arch rubbers.

11. Cooling

A replacement water radiator of similar construction and design (save cross flow operation) to original specification is permitted subject to there being no modification to the original bodywork.

Mounting of the radiator must be in the original position being parallel with the radiator support panel and utilising the original mounting points.

Its design, construction and fitment must serve no purpose other than to cool the engine coolant. It is permitted to remove the original radiator fan and aluminium spacer in which case a replacement electric radiator fan is permitted.

The heater hoses and manifold heating hoses may be removed and the resulting holes may be plugged. A water filter may be fitted in the top radiator hose.

12. Electrical

Mounting of the ignition coil maybe relocated and mounted to the brake pressure differential switch mounting bolt.

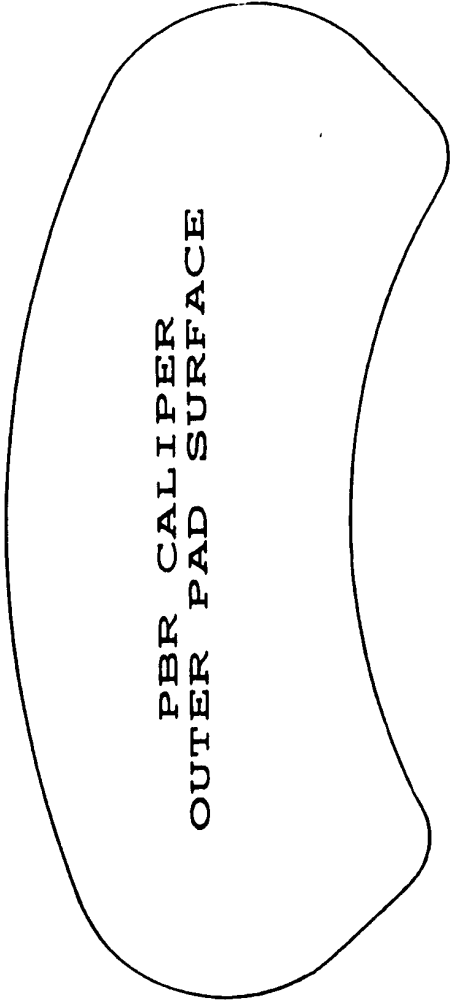
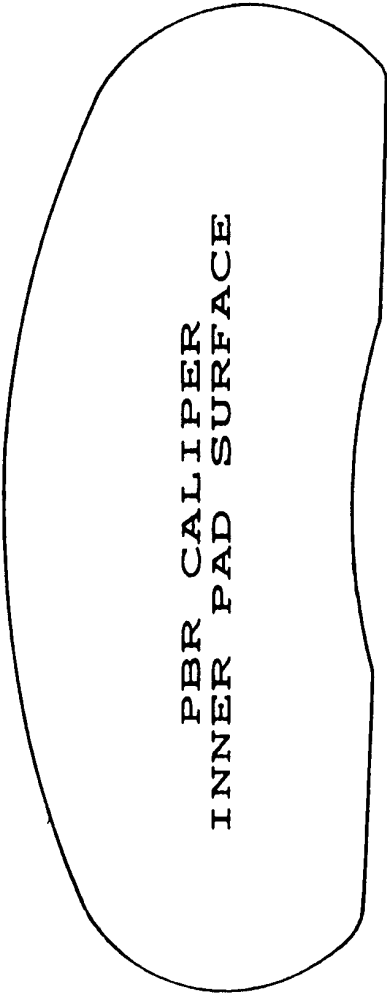

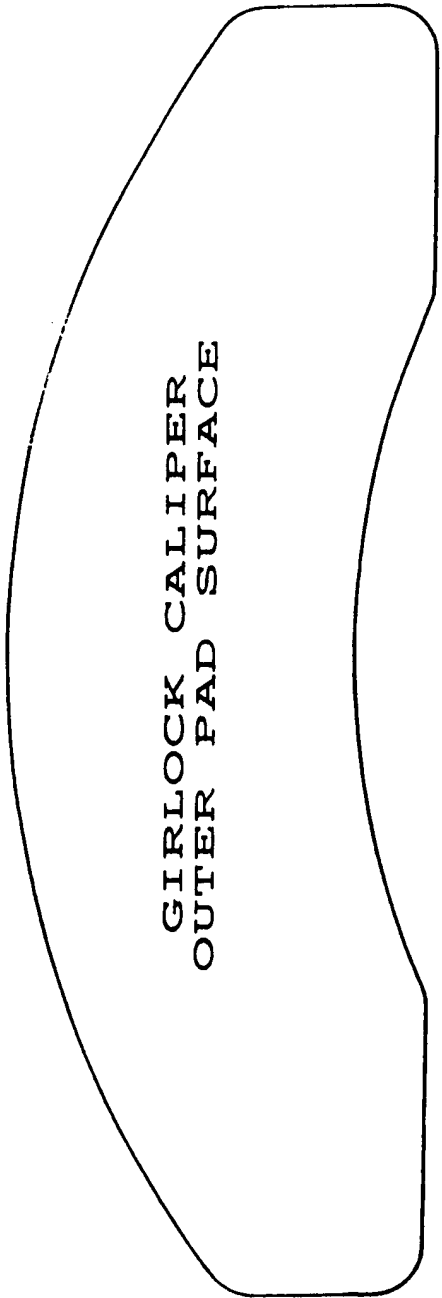
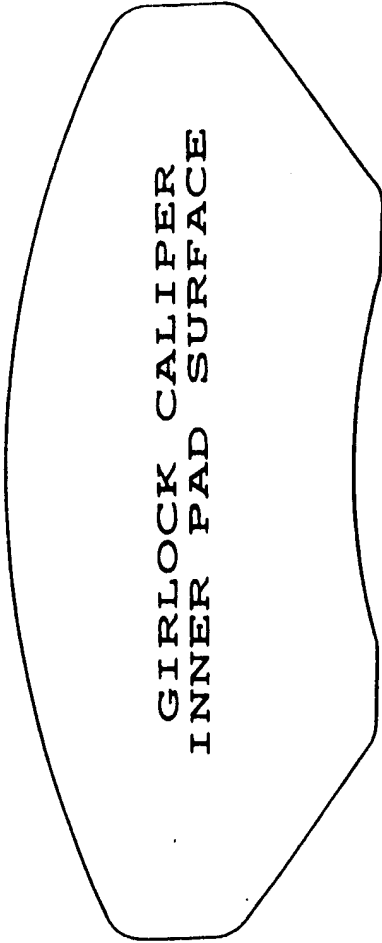

TECHNICAL MANUAL **GROUP 3H HQ HOLDEN'S**

**Prepared and Authorised by HQ RACING AUSTRALIA
In conjunction with Motorsport Australia**

1. INTRODUCTION

In accordance with the CAMS rules pertaining to Group 3H HQ Holden's, this manual and the regulations for the 3H HQ Holden's as published in the Motorsport Australia manual will be the basis for examinations of eligibility of group 3H HQ Holden racing cars.

1.1 INTERPRETATIONS

All regulations must be strictly adhered to, and unless a modification or departure from a standard HQ Holden is specifically allowed in the regulations then it is prohibited. All components must remain as originally manufactured unless specifically allowed in the regulations. The manufacturers sitting and integrity of components must be respected unless specifically allowed in the regulations. The following procedures will apply when seeking and obtaining interpretations to the Motorsport Australia regulations or this manual.

- 1.1.1 All requests for interpretation must be made in writing to the Technical Manager at Motorsport Australia.
- 1.1.2 The Technical Manager may make a determination, or circulate such requests to all state HQ Association Technical Officers to resolve any ambiguous interpretations of the regulations.
- 1.1.3 The State Technical Officers must return their Interpretation To the originating Technical Officer within seven (7) days of receiving the request.
- 1.1.4 In the absence of unanimous agreement between the state Technical Officers within thirty (30) days, the matter shall be referred to the eligibility committee of Motorsport Australia for determination.
- 1.1.5 The interpretation shall be issued to each state association for inclusion in the appropriate appendix of this manual, and for distribution to the members.
- 1.1.6 A written reply shall be given to the member requesting the interpretation.

1.1.7 If required the regulation that led to the need for interpretation should be subject to revision via consultation with Motorsport Australia.

1.2 SCRUTINEERING POLICY AND AUTHORITY

The following scrutineering policy and authority applies to the scrutineering of HQ Holdens for eligibility.

- 1.2.1 The state Technical Officer may at any race meeting he attends, advise the Chief Scrutineer of the meeting on matters relating to eligibility.
- 1.2.2 Engines, gearboxes and diffs are to be sealed in accordance with the sealing procedures in this manual.
- 1.2.3 Persons eligible to seal engines, gearboxes and diffs will be appointed by each State Association.
- 1.2.4 Each State Association will publish, for the benefit of their members, the names and addresses of authorized sealers, and will notify the Technical Manager at Motorsport Australia.
- 1.2.5 No sealer shall engage in collusion to seal an engine/gearbox or diff to provide a material advantage to a particular competitor.
- 1.2.6 Seals and approved sealing wire shall be provided by each State Association, the Association shall keep records of seals going to each sealer.
- 1.2.7 The sealer will be issued with the approved paperwork necessary for him to record the required information. The paperwork will record the number and location of every seal, the number of the CAMSHAFT, and any comments the sealer feels necessary to record. The paperwork will be in triplicate, the top copy going to the owner, the second copy to be forwarded to the State Association monthly, and the third copy is to be retained by the engine sealer. An audit is to be made annually of all seals, this audit is to be carried out by an Association approved person who will sign and date the sealers records if found to be correct.
- 1.2.8 It is the responsibility of the competitor to maintain the condition of a competition vehicle to a standard satisfactory to race scrutineers.
- 1.2.9 The seals and sealing books will always remain the property of HQRA and HQRA retain the right to remove seals from a race vehicle.

TECHNICAL ADVISER & STATE BASED ELIGIBILITY / TECHNICAL OFFICER

Selection Criteria

1. A sound working knowledge of the Motorsport Australia Manual of Motor Sport and have a Motorsport Australia General Official Accreditation.
2. Be conversant with the application of the General Requirements regarding schedules and Specifications with particular reference to Group 3H
3. To have an intimate knowledge of, be able to interpret and apply the specifications contained in the Group 3H Regulations, Technical Regulation manual and to be thoroughly familiar with the workshop and parts manuals as published by General Motors-Holden Automotive Ltd.
4. The applicant must have a mechanical background. They should have a thorough knowledge of engine building procedures and specifications and mechanical repairs.
5. They must be conversant with and be capable of using specific measuring devices for measuring such dimensions as bore, stroke of crankshafts, engine blocks, camshafts, cylinder heads and flywheels etc.
6. Where possible, they should have a racing (competition or preparation) knowledge of the sport so as to be able to better understand and relate to competitors in explaining the rules as laid down in the Motorsport Australia manual of motor sport
7. For Technical Adviser it is preferable that they have served as an HQ Eligibility / Technical Officer for a period of at least 12 months with an HQ Racing Association within the last 3 years.
8. The State based Eligibility / Technical Officer should be able to attend most race meetings in his or her State of residence.
9. If present at interstate race meetings, he or she may be called on in conjunction with, or in the absence of, that State's Eligibility / Technical Officer to carry out their duties
10. Prior to the commencement of practice or competition each day at any race meeting they intend to exercise their authority, they may make themselves known to the Chief Scrutineer of the meeting and advise of their intentions in regard to that meeting.

11. In conjunction with the Chief Scrutineer, the State based Eligibility / Technical Officer shall carry out such eligibility checks as they deem necessary.
12. The State based Eligibility / Technical Officer can be called upon to give evidence or interpretations at any Steward's or any other judicial enquires.
13. In the event of any matter requiring interpretation not covered within the Group 3H regulations or Technical Regulation manual, it should be referred to the State Eligibility / Technical Officer who in turn may contact the National Technical Adviser.
14. They should make himself available to competitors and Motorsport Australia alike at their convenience to answer technical questions at the questioner's expense.
15. They should train an understudy as there eventual equal or replacement
16. It is preferred that an appointed Technical Adviser / Eligibility Officer not currently be competing in Group 3H or have any allegiance or links to a Group 3H team or vehicle, or be a Group 3H car constructor or engine builder.

COMPONENT SEALER

Duties

1. Each State Association is to appoint at least one or more Group 3H component sealer as is required by member numbers and member's location.
2. The sealer should be readily available for the purpose of after hour sealing within reason.
3. The sealer should be available to attend most race meetings in his or her state of residence where Group 3H are competing.
4. A component sealer must have a mechanical background. They should have a thorough knowledge of engine, gear box and differential building procedures, specifications and mechanical repairs.
5. They must be conversant with and be capable of using specific measuring devices for measuring such dimensions as bore, stroke of crankshafts, engine blocks, camshafts, cylinder heads and flywheels etc.
6. It is preferred that an appointed sealer not be a current competitor or have an allegiance or links to a current competing Group 3H racing team.

7. A component sealer will not have the authority to seal ANY Group 3H race car component the he or she has had any involvement in the assembly or repair of.
8. Component sealing and sealing procedures are to be in line with the current HQRA Technical Regulations manual.
9. A component sealer must keep a log of all seals, date and placement of the seal.
10. This log must be forwarded to the State based HQRA Delegate on a regular basis.
11. Distribution of component seals to the State appointed component sealers will be by liaison between the State Based HQRA Delegate and the National Technical Commissioner.
12. Cost of seals and sealing wire will be borne by the States controlling Group 3H body.

2. SEALING PROCEDURES

2.1 INTRODUCTION

The following scrutineering procedures apply to all racing HQ HOLDEN'S and must be carried out by registered sealers. Prior to any HQ component being sealed the competitor MUST supply their current HQRA Membership Card, the vehicle Log Book and the current HQRA seal sheet as is related to the components to be sealed. On completion of scrutineering (ie: component assembly), approved seals as supplied by HQRA, are the only seals that shall be recognised for this purpose are 'Roto Seals', are to be secured by the sealer on the approved sealing wire, so as to ensure that key engine, transmission and differential parts cannot be modified or replaced without removing the seals. All relevant sealing documents must be made available upon request, failure to produce seal sheet will result in a penalty of \$50.00

2.2 SCRUTINEERING OF ENGINES

All engine measurement must be carried out with the components at ambient temperature to avoid errors arising from differential expansion.

2.2.1 CHECKING THE INTERNAL COMPONENTS OF THE ENGINE

Before assembling examine all parts for signs of modification, e.g. addition or removal of material, polishing, grinding etc., other than which is constant with normal automotive general machining practices, reconditioning procedures and balancing.

Check that all components comply with the regulations. It is not permitted to apply coatings to any component. Bead blasting is an accepted method of cleaning.

Connecting rods	(Standard).
Connecting rod bolts	(Standard or replacements units).

The use of aftermarket con rod bolts is permissible. No modification or machining of the con rod is permissible for the purpose of con rod bolt fitment.

Crankshaft	(Standard, other than reconditioning of journals and heat or chemical treatment).
Pistons	(Must be of non forged construction).
Valve Lifters	(Must be hydraulic operation, maximum diameter 0.8428”).
Block	(Check that the block has not been angle planed).
Oil Strainer	(Is free, but the pick up tube is to remain unmodified above the strainer).
Bore (Max)	(3.694”).
Stroke	(3.250”).

NOTE: If piston coating is suspected, a film thickness tester maybe used or applying a small amount of Hydrochloric Acid (available hardware stores) to the crown of the piston and observe reaction. Any noticeable reaction would indicate the lack of any coating.

2.2.2 CYLINDER HEAD ASSEMBLY

Check cast numbers	2811930 / 9937262
	Check that the head has not been angle planed.
Valve guide bore	Inlet Min 0.3420” Exhaust Min 0.3430”
Valve head size	Inlet Max 1.675” Exhaust Max 1.375”
Valve Spring	One only.
Rocker Arms & Bridges	Standard

Valve head to combustion chamber wall dimension 0.125" Max
The valve guide boss must not be modified (diagram 1/A).
The area around the spring seat can be machined to obtain the correct height (diagram 1/B).
Under the valve seat check that the throating does not go beyond the valve guide boss (diagram 1/C).

Multiple or compound taper machining from the valve seat area towards the valve guide boss is not allowed. Machining of the throat must be a constant taper and /or parallel to the axis of the valve guide. *This also applies to all valve seat inserts.*

The valve guide boss may be machined to achieve a minimum O/A guide length of 2.0" (50.8mm). All machining must use the guide axis for the cutter. No further modification is permitted except for re-radiusing in the top of the throat. (diagram 1/C)

No burrs etc. formed by the cutters are to be removed by any means. Examine closely the combustion chamber, the inlet and exhaust ports of the cylinder head to ensure that no modification, (other than which is permitted) has been carried out.

Where the throat meets the port a distinct edge is formed, it cannot be modified (diagram 1/D)

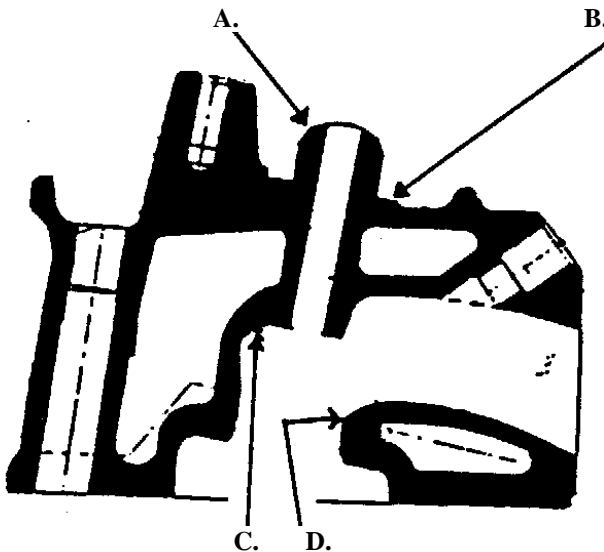

Diagram 1.

Unswep Volume Procedure

1. Start with CLEAN (as in spotless) heads.
2. Be sure to use the same type of spark plugs for CCing that you intend to run.
3. Block the head up so that the head surface is flat and even.
4. Coat the periphery of the combustion chamber with grease – white heat-resisting brake grease is easy to see and works very well.
5. Place the HQRA approved Plexiglas plate over the chamber, with the hole on the high side and the counter sink up. Press evenly and firmly to insure a perfect seal.

Carefully assemble the burette, stand and clamp.

Specification of Burette 'Cat No: 13918, ISO 9001-14001certified'

6. Using blue kerosene as a measuring fluid, fill the burette to the “O” line. NOTE: The surface of the column of fluid will appear to be concave (or sunken) in the center. This is known as *meniscus*. For accurate results, align the marks on the burette with the lowest (sunken) portion of the fluid for all measurements.
7. With the burette positioned over the countersunk hole, and the head FIRMLY blocked, slowly open the stop-cock and begin filling the chamber. Watch for leaks at the seal of the plate and the head surface (this is where the white grease helps). If a leak develops, be very patient and START OVER.
8. Fill the chamber until the fluid just touches the BOTTOM of the hole. Be sure ALL air bubbles are out.
9. Carefully read and record the amount of liquid metered into the chamber. (Remember what was mentioned about meniscus.)

2.2.3 CHECKING OF CAMSHAFTS

This check should be carried out by ALL engine sealers.

To carry out this check you will need the following:

1. A dial indicator with magnetic base.
2. A plate that will mount onto the head using the rocker cover attaching studs.

The following is the procedure to be used.

Mount the plate on the side of the head so the dial indicator when sitting on the plate can reach the push rods of any cylinder.

From the cylinder you choose, remove the rocker arms and let the dial indicator rest on the inlet pushrod.

Turn the motor over so that you are sure the lobe of the cam is in the fully closed position.

Zero the dial indicator, turn the motor over in the correct direction of rotation until the indicator reads .035”.

Remove the indicator from the inlet valve pushrod and install it on the exhaust pushrod, zero the indicator, continue to rotate the motor until the indicator stops moving, it should read between .029” - .031”.

Alternatively, you can use the measurement of .070” for the inlet valve and .010” for the exhaust.

If after carrying out the above check you cannot get the correct readings, contact Clive CAMS straight away.

In the event of any discrepancy, the camshaft is to be held by the engine sealer pending further action.

2.3 SCRUTINEERING OF GEARBOXES

Check the cluster	(Part NO. 7434307)
Ratios	1 st - 3.07:1 Teeth 17/27
	2 nd - 1.68:1 23/20
	3 rd - 1.00:1 29/15
	Rev. 3.59:1

The original three-speed manual gearbox may be used. The extension housing may be replaced by an extension housing sourced from a four speed M20 or M21 gearbox.

Bell housing	Late model bell housing can be used.
--------------	---

Check that there have been no modifications carried out.

2.4 SCRUTINEERING OF DIFFERENTIALS

Check that no modifications have been made to any of the diff gears or the diff gear carrier. The sun/planetary gears must rotate freely by hand prior to sealing of the diff and once the diff assembly is complete the suspended wheel must rotate freely at all times.

Method for initial testing of diff gear freedom is as follows: Vehicle to be jacked up to allow both rear wheels to rotate, either wheel is to be rotated by hand and opposite wheel to be observed, opposite wheel is to remain stationary or rotate in opposite direction to rotated wheel. Failure to comply is to result in further investigation.

2.5 ATTACHING SEALS

- 2.5.1 Seals are to be attached as per Roto seal instruction sheet. The seal, and/or the part the seal is sealing on to the vehicle, are not to be able to be removed without breaking the seal.
- 2.5.2 Components to be sealed are;
Engine (head, sump, timing cover and/or oil pump) Gearbox and Differential.
- 2.5.3 When sealing the head, a hole is to be drilled through the casting, which is on the right hand side in the centre of the head. A hole will be drilled in the casting, which is situated between the side cover plates on the block.
- The sealing wire will be threaded through the hole in the head, passed through the hole in the block, and the seal is to be fitted with the ends in the seal.
- 2.5.4 To seal the sump on the right hand side, a hole is to be drilled in the cast web (vertical) of the engine mount front bolt, and a hole in the edge flange of the sump.
Again, a wire is to be threaded between these two components and the seal fitted. To seal the sump on the left hand side do the same as above, but drill the front horizontal web, this makes it easier to read the seal when the motor is assembled and in the vehicle. Alternative methods of sealing sumps is acceptable save that the sump must be sealed on both sides.
- 2.5.5 To seal the camshaft, seal the timing cover on by drilling the heads of the two bolts located just below and to the drivers side of the water pump inlet or seal the oil pump on by drilling the heads of two pump to block attaching bolts.
- 2.5.7 To seal the gearbox drill two holes in two side cover attaching bolts, or two bolts on the extension housing.
- 2.5.8 To seal the diff drill two holes in the retaining bolts/nuts on either the rear cover (Salisbury) or the retaining bolts (Banjo).

3. BRAKE DIAGRAMS

Optional rear brake cooling

Inlet and outlet holes will have metal removed by drilling or other suitable method to a maximum diameter of 40mm.

AIR OUT

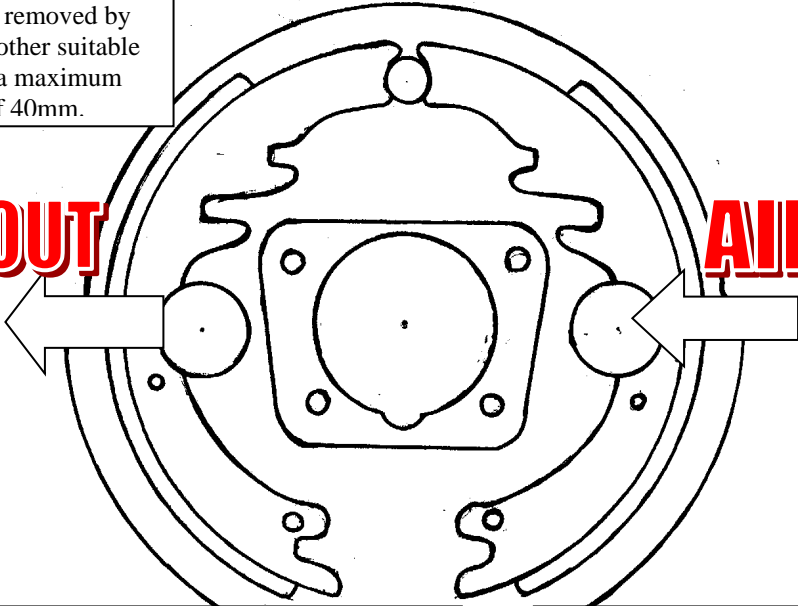

AIR IN

Centre line of inlet and outlet holes to be in line with center of backing plate in a horizontal plane plus or minus 10mm. Centre of inlet and outlet holes to be 80mm from center of backing plate plus or minus 5mm.

Air inlet hole with 40mm OD tube welded to rear of backing plate. Length of tube between 40mm and 80mm, for inlet and/or outlet hole.

Optionally, the same specified area of inlet and outlet holes may be drilled with any combination of smaller holes to provide additional strength, although not necessary.

Brake ducting allowed to existing rule sizes. Suggested clamping point is to lower spring saddle area.

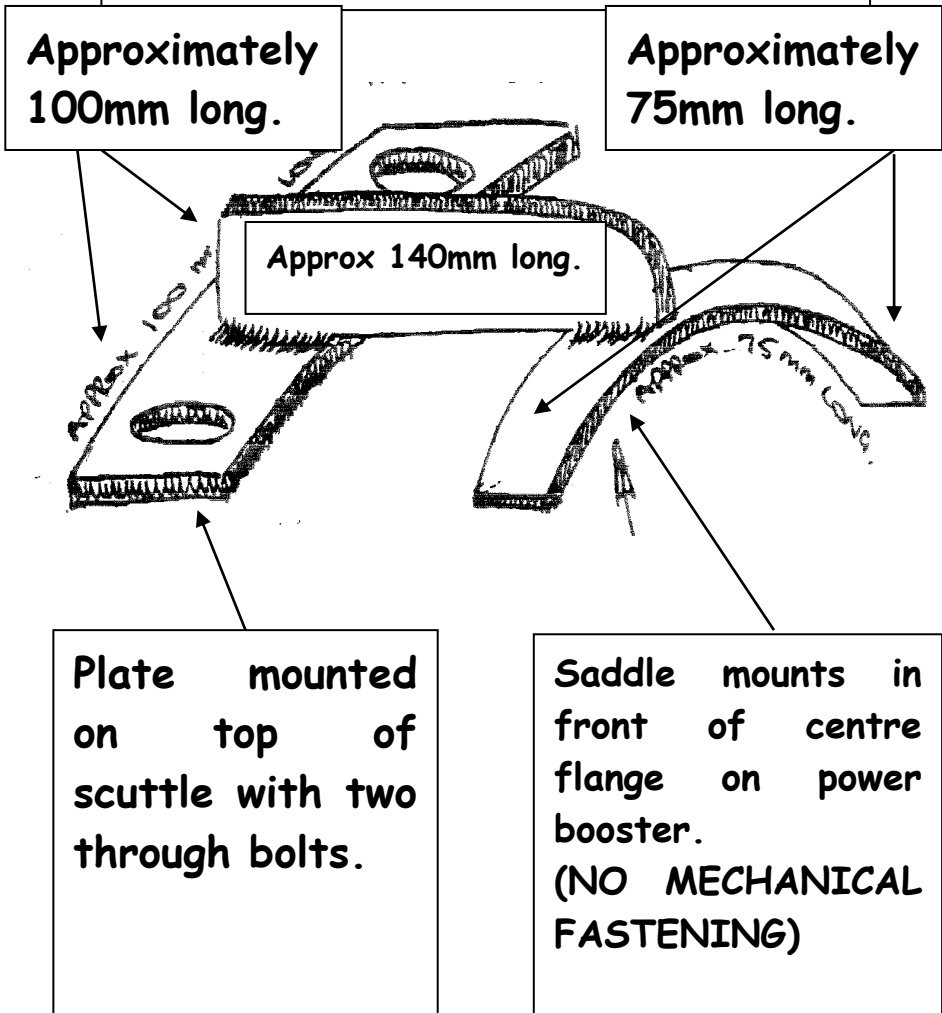

Brake Booster Bracing.

Fitment of a simple bracket is optional. This diagram is the preferred design but not mandatory.

Scuttle panel brace.

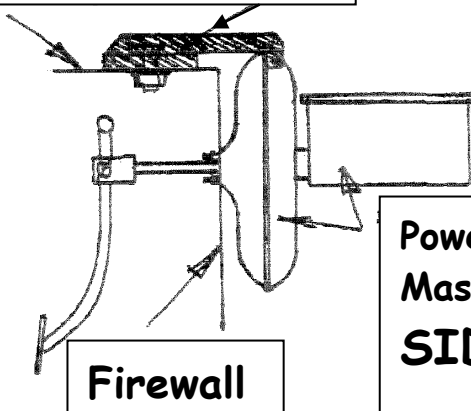

Power booster,
Master cylinder.
SIDE VIEW

Scuttle panel

Brace

Power booster
Master Cyl
Assembly
(Master Vac)

**PLAN
VIEW**

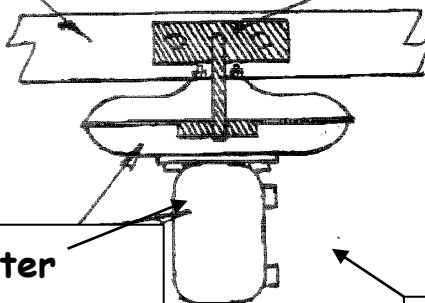



D.A.R.T. Racing

Specialising in:

Race Car set ups
Spring Testing

Carby Rebuilds
Roll Cages

Exhaust Systems
REBUILD Engines, Gearboxes & Diffs

Flow Testing
Tyres / **Buffing**

Mobile: 0418 515 682 David